



Construction equipment

## SCHEDA PRODOTTO

### SAFETY EQUIPMENT

#### Material handling bin

CST-D

Heavy duty goods carrying cage, fitted with forklift pockets and lifting eyes.

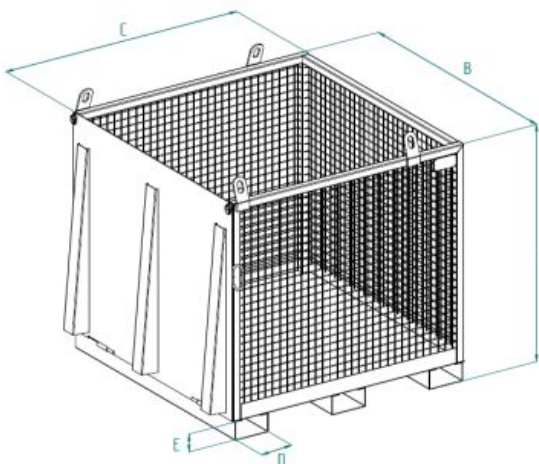

MODEL	CAP. (Kg)	DIMENSIONS (mm)					WEIGHT (kg)
		A	B	C	D	E	
CST-D	2000	1232	1346	1360	180	65	200



**Boscaro srl**

Via G. Cederle, 1 - 36020  
Campiglia dei Berici (Vicenza) Italy

Tel +39 0444 866520  
Fax +39 0444 866350  
P.IVA: 00672450244